

APPROACH WITH ADJACENT SIDEWALK



APPROVED	REVISIONS
	12/18/2014
PUBLIC WORKS DIRECTOR	
DATE	

CITY OF HAMILTON
 DEPARTMENT OF PUBLIC WORKS
 STANDARD DRIVEWAY OPENING
 WITH ADJACENT SIDEWALK
 (PAGE 1 OF 2)

HC. 20.04.011-1

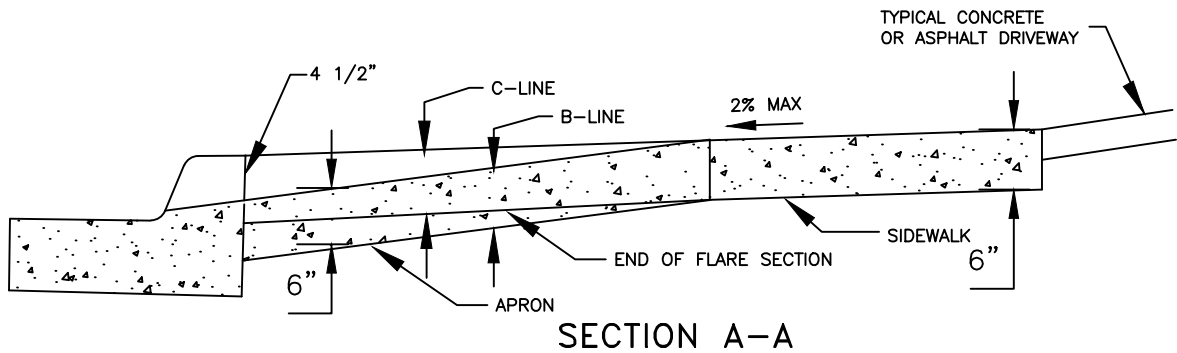
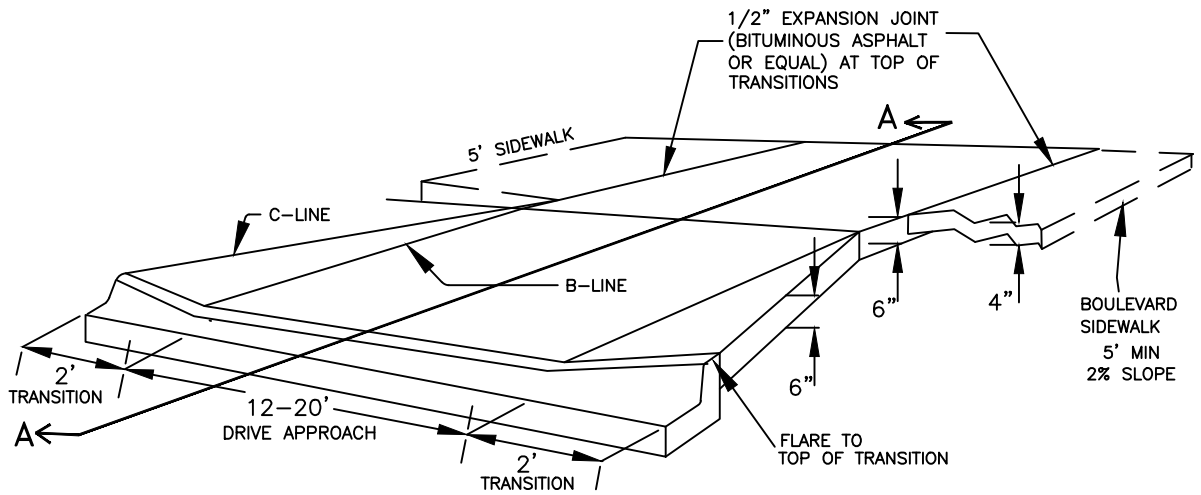

APPROACH WITH BOULEVARD SIDEWALK



APPROVED	REVISIONS
	12/18/2014
PUBLIC WORKS DIRECTOR	
DATE	

CITY OF HAMILTON
 DEPARTMENT OF PUBLIC WORKS
 STANDARD DRIVEWAY OPENING
 WITH BOULEVARD SIDEWALK
 (PAGE 2 OF 2)
 HC. 20.04.011-2